



Portable Resonant Vertical
Antenna
(CHA PRV)
Operator's Manual

Nevada - USA

WWW.CHAMELEONANTENNA.COM



VERSATILE – DEPENDABLE – STEALTH – BUILT TO LAST

Rev. 9/27/2023

Table of Contents

Introduction.....	3
HF Propagation.....	4
CHA PRV SOTA Kit Components	6
CHA PRV POTA Kit Components	9
Ground Spike Mount Setup.....	10
Operation of the Portable Resonant Vertical	12
Operation on 6 and 2 meters	14
Tuning Theory.....	15
Recovery Procedure	16
Troubleshooting	16
Modular Upgrades	17
Accessories	21
Specifications.....	22
References.....	22
Chameleon Antenna™ Products	23



Be aware of overhead power lines when you are deploying the CHA PRV. You could be electrocuted if the antenna gets near or contacts overhead power lines.

Photographs and diagrams in this manual may vary slightly from current production units due to manufacturing changes that do not affect the form, fit, or function of the product.

All information on this product and the product itself is the property of and is proprietary to Chameleon Antenna™. Specifications are subject to change without prior notice.

Introduction

Thank you for purchasing and using the Chameleon Antenna™ Portable Resonant Vertical (CHA PRV) antenna. The CHA PRV is a finely crafted lightweight and rugged antenna -- intended for extreme portable use, such as: Parks On the Air (POTA), Summits On the Air (SOTA), and other outdoor radio adventures where an efficient but highly portable antenna is required. It is also ideal for radio enthusiasts who live in an RV, apartment or condominium - where you have only a small balcony or patio. Chameleon Antenna™ designed the CHA PRV to complement the new generation of small multi-band/multi-mode QRP transceivers, like the Icom IC-705, Xiegu G90 or XG100, LAB 599 TX500, or the Yaesu FT-817/818.

The CHA PRV antenna will operate from 5.4 – 100.0 MHz continuous and the 40 – 2 meter Amateur Service bands without an antenna tuner. Tuning the CHA PRV is easy – you only need to adjust the height of the Multi-Configuration Coil when changing bands on 40 through 10 meters.

The PRV SOTA (LIGHT KIT) contains the Multi-Configuration Coil, a telescoping 58 in. stainless steel whip, ground Spike Mount, a Puck Hub, four 12.5 ft. radial wires with line winders, a Variable Length Counterpoise, a Camera Tripod Adapter, and 12 ft. of RG-58 coaxial cable with an integrated RF choke.

The PRV POTA (HEAVY KIT) contains all the components of the PRV SOTA kit plus the Universal Clamp Mount, and a set of two 12 in. Extender Rods to elevate the base of the antenna for improved performance.

The CHA PRV is designed to be highly modular and can use components and accessories from the popular Modular Portable Antenna System (MPAS) 2.0 and MPAS Lite antenna systems.

This antenna also has flexible mounting options. In addition to the included Spike Mount for ground mounting, the CHA PRV

can use the Universal Clamp Mount or the Jaw Mount for attaching the antenna to a picnic table, balcony railing, fence post, or other convenient support structure.



Plate 1. CHA PRV SOTA Kit.

Using the new Camera Tripod Adapter, you can attach the CHA PRV to a heavy-duty camera tripod or monopod.

This antenna does not require an antenna tuner when properly tuned. Antennas built by Chameleon Antenna™ are versatile, dependable, stealthy, and built to last. Please read this operator's manual so that you may maximize the utility you obtain from your CHA PRV.

HF Propagation

HF radio provides relatively inexpensive and reliable local, regional, national, and international voice and data communication capability. It is especially suitable for undeveloped areas where normal telecommunications are not available, too costly, or scarce, or where the commercial telecommunications infrastructure has been damaged by a natural disaster or man-caused events.

Although HF radio is a reasonably reliable method of communication, HF radio waves propagate through a complex and constantly changing environment and are affected by weather, terrain, latitude, time of day, season, and the 11-year solar cycle. A detailed explanation of the theory of HF radio wave propagation is beyond the scope of this operator's manual, but an understanding of the basic principles will help the operator decide what frequency and time of day will support their communication requirements.

HF radio waves propagate from the transmitting antenna to the receiving antenna using two methods: ground waves and sky waves.

Ground waves are composed of direct waves and surface waves. Direct waves travel directly from the transmitting antenna to the receiving antenna when they are within the radio line-of-sight. Typically, this distance is 8 to 14 miles for field stations. Surface waves follow the curvature of the Earth beyond the radio horizon. They are usable during the day and under optimal conditions, up to around 90 miles, see table (1). Low power, horizontal antenna polarization, rugged or urban terrain, dense foliage, or dry soil conditions can reduce the range very significantly. The U.S. Army found that in the dense jungles of Vietnam, the range for ground waves was sometimes less than one mile.

Sky waves are the primary method of HF radio wave propagation. HF radio waves on a frequency below the critical frequency (found by an ionosonde) are reflected off one of the layers of the ionosphere and back to Earth between 300 and 2,500 miles, depending upon the frequency and ionospheric conditions, HF radio waves can then be reflected from the Earth to the ionosphere again during multi-hop propagation for longer range communication. The most important thing for the operator to understand about HF

radio wave propagation is the concept of Maximum Usable Frequency (MUF), Lowest Usable Frequency (LUF), and Optimal Working Frequency (OWF).

Frequency	Distance	Frequency	Distance
2 MHz	88 miles	14 MHz	33 miles
4 MHz	62 miles	18 MHz	29 miles
7 MHz	47 miles	24 MHz	25 miles
10 MHz	39 miles	30 MHz	23 miles

Table 1. Maximum Surface Wave Range by Frequency.

The MUF is the frequency for which successful communications between two

points is predicted on 50% of the days of in a month. The LUF is the frequency below which successful communications are lost due to ionospheric losses. The OWF, which is somewhere between the LUF and around 80% of the MUF, is the range of frequencies which can be used for reliable communication. If the LUF is above the MUF, HF sky wave propagation is unlikely to occur.

The HF part of the Radio Frequency (RF) spectrum is usually filled with communications activity and an experienced operator can often determine where the MUF is, and with less certainty, the LUF by listening to where activity ends. The operator can then pick a frequency in the OWF and attempt to establish contact. Another method is using HF propagation prediction software or an online service, such as the *Voice of America Coverage Analysis Program (VOACAP)*, which is available at no cost to download or use online at www.voacap.com. The operator enters the location of the two stations and the program shows either a chart or wheel with the predicted percentage of success based on frequency and time. ALE, which is the standard for interoperable HF communications, is an automated method of finding a frequency in the OWF and establishing and maintaining a communications link.

Even under optimal conditions, there is a gap between where ground waves end (around 40 to 90 miles) and the sky wave returns to Earth on the first hop (around 300 miles). NVIS propagation can be used to fill this gap. To use NVIS propagation, the frequency selected must be below the critical frequency. Therefore, NVIS propagation can normally only be used on frequencies from around 2 to 10 MHz. Frequencies of 2 – 4 MHz are typical at night and 4 – 8 MHz during the day. The CHA PRV, like most vertical antennas, is not designed to utilize NVIS propagation.

CHA PRV SOTA Kit Components

The CHA PRV SOTA kit is comprised of the following components, see plates (2) and (3).



Plate 2. Antenna Components.

- A. Multi-Configuration Coil.** The Multi-Configuration Coil (CHA MCC) provides base-loaded inductance for the vertical antenna and is continuously adjustable for resonance at the operating frequency.
- B. Telescoping Whip.** The Telescoping Whip is the radiator for the vertical antenna. It is made of stainless steel, is 58 inches long when extended, and 17 1/2 inches long when collapsed.
- C. Coaxial Connector.** The Coaxial Connector is an SO-239 socket on the side of the Multi-Configuration Coil and is used to connect the Coaxial Cable to the Multi-Configuration Coil.
- D. Tuning Tube.** The Tuning Tube is the movable cover over the loading coil that increases the impedance of the loading coil as it is moved up and decreases it as it is moved down, thus changing the resonant frequency of the antenna.

- E. **Lock Knob.** The Lock Knob is used to lock the Tuning Tube in place once resonance is reached.
- F. **Coaxial Cable.** Coaxial Cable is 12 feet of RG-58 with an integrated RF Choke. It is used to connect the CHA PRV to the Radio Set. Longer lengths available as options. **This antenna requires an RF Choke in the feedline.**
- G. **Spike Mount.** The Spike Mount drives into the ground and provides a ground mount for the CHA PRV.

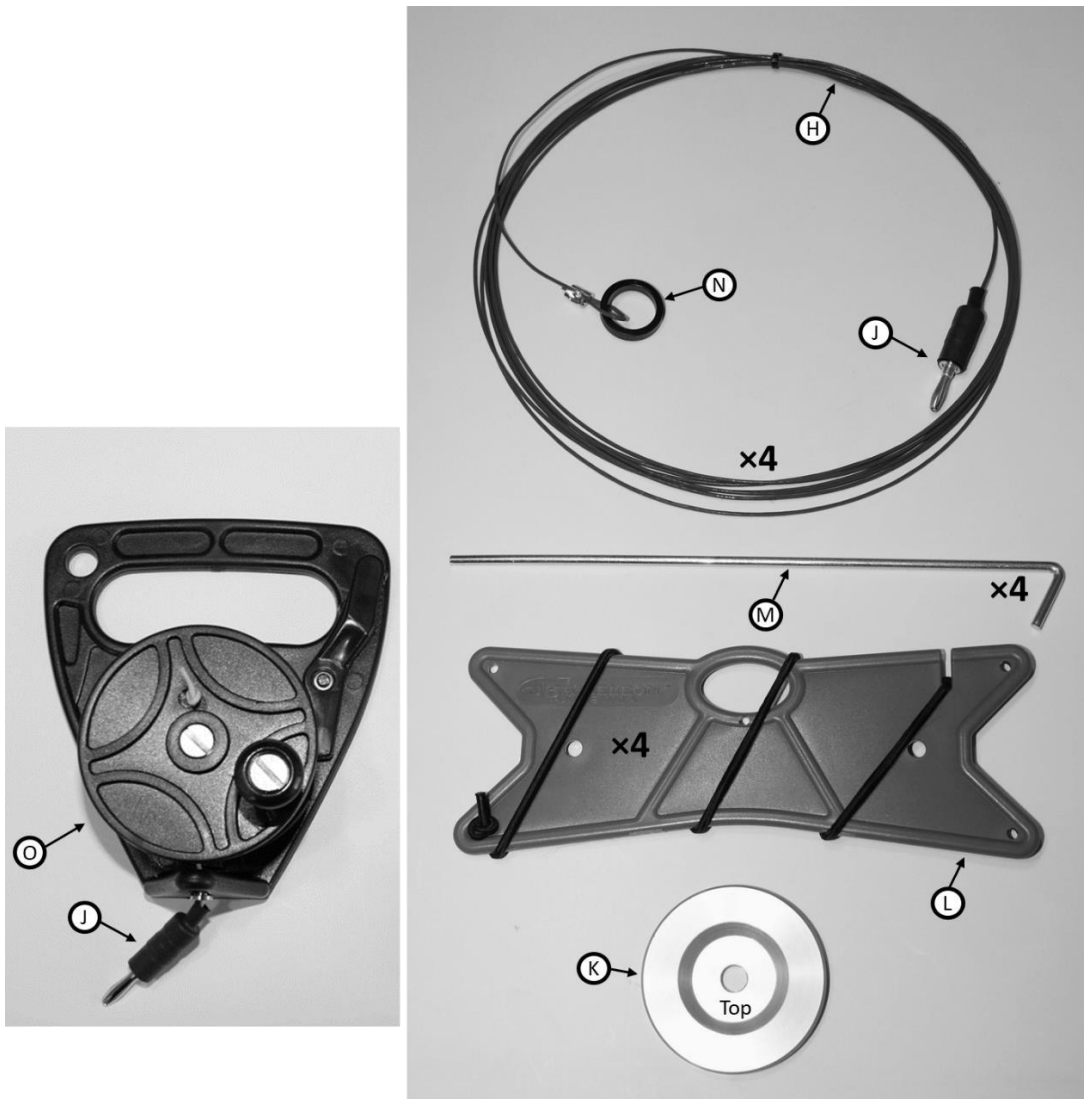

Plate 3. Counterpoise Components.

- H. **Counterpoise Wire.** The basic antenna is supplied with four 12.5 ft. Counterpoise Wires.

- I. **Camera Tripod Adapter.** The Camera Tripod Adapter (*not pictured*) is used to mount the CHA PRV to a heavy-duty camera tripod, monopod, or trekking pole with camera mount. One end has a 3/8 in. x 24 threaded socket for the base of the MCC and the other has a 1/4 in. x 20 threaded socket for the camera tripod.
- J. **Counterpoise Connector.** The Counterpoise Connector is a banana-style plug located at the end of the Counterpoise Wire and is used to connect it to the Puck.
- K. **Puck.** The Puck (CHA PUCK) hub enables connection of up to six Counterpoise Wires to the antenna.
- L. **Line Winders.** The Line Winders are used for storage of the Counterpoise Wires.
- M. **Stakes.** The Stakes are used to anchor the far ends of the Counterpoise Wires to the ground.
- N. **Insulator Ring.** An Insulator Ring is located at the end of each Counterpoise Wire.
- O. **Variable Length Counterpoise.** The Variable Length Counterpoise is a highly flexible method of providing the CHA PRV a necessary counterpoise from 5.3 to 54.0 MHz (60 – 6 meters).

CHA PRV POTA Kit Components

In addition to the components included in the CHA PRV SOTA kit, the CHA PRV POTA kit contains the following (as shown in Plate [4]):

- P. CHA UCM.** The Universal Clamp Mount is a heavy-duty clamp-style mount intended for use on balcony railings, tables, and other fixtures with flat horizontal surfaces with edges.
- Q. 12 In. Extender Rods.** Two 12 in. Extender Rods are included in the CHA PRV POTA kit. The Extender Rods are installed below the MCC and Puck hub and raise the base of the antenna 24 in. above the Spike Mount or CHA UCM. Raising the base of the antenna will improve antenna performance.



Plate 4. CHA PRV POTA Kit.

Ground Spike Mount Setup

Setup of the CHA PRV is quick and easy. Use the following procedure to setup the CHA PRV antenna using the ground Spike Mount. Refer to figure (1) while performing setup procedure.

Caution: Do not attempt to drive the assembled antenna into the ground by grasping the Multi-Configuration Coil or striking the top of the Multi-Configuration Coil. Permanent damage to the Multi-Configuration Coil will occur. Instead, drive the Spike Mount into the ground first and then assemble the components onto it, as described in the setup procedure.

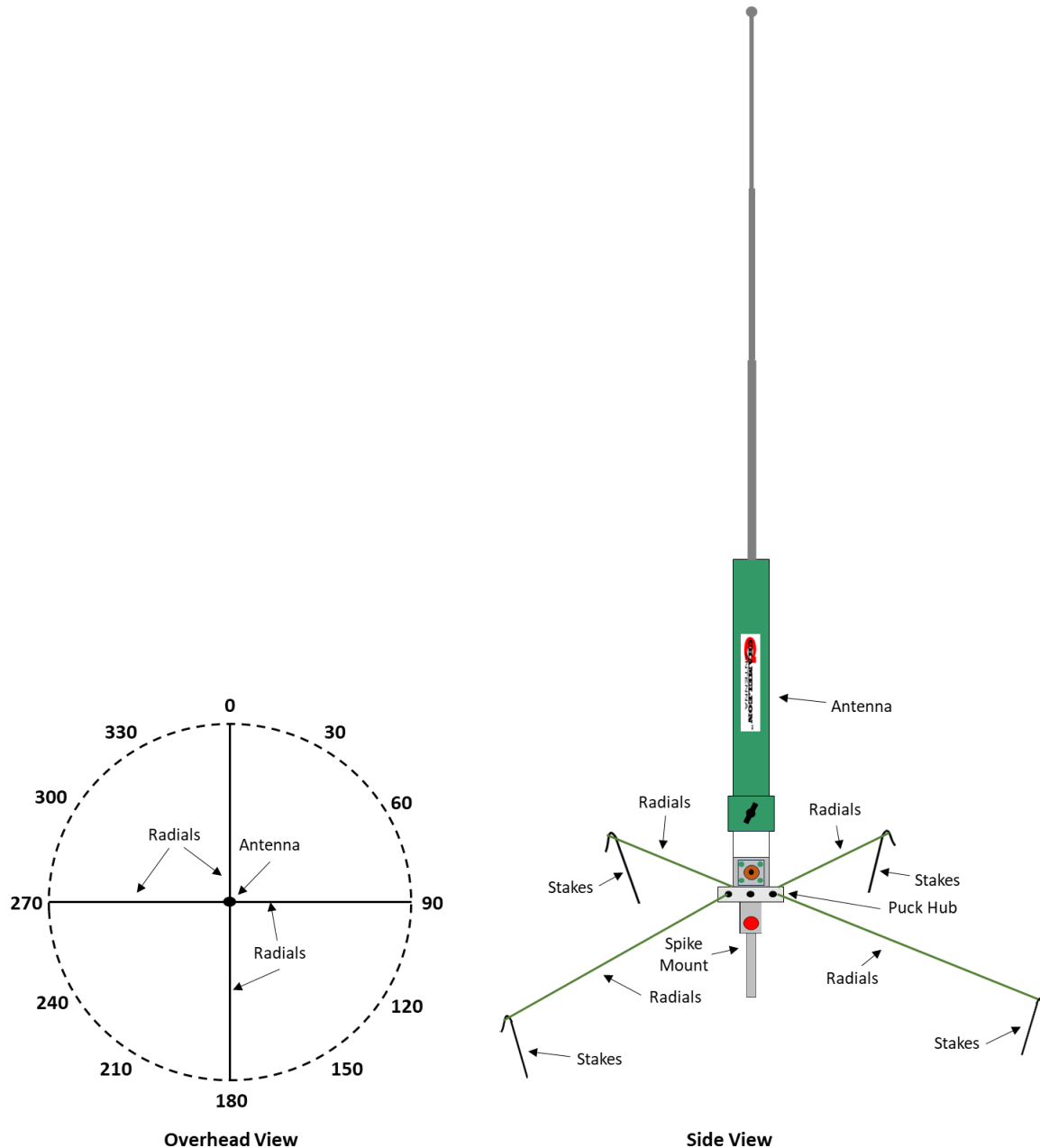

Figure 1. CHA PRV Ground Spike Mount Vertical.

1. Select a site large and clear enough to permit setup of the antenna, including counterpoise wires (see figure [1]).
2. Using a plastic camping hammer or rubber mallet, drive the Spike Mount (G) into the ground in the center of the circular site.
3. Thread the Puck (K) hub onto the stud at the bottom of the Multi-Configuration Coil (A) and tighten hand tight. *The side with the indentation is the top.*
4. Thread the Multi-Configuration Coil stud onto the Spike Mount and tighten hand tight.
5. Thread the stud on the bottom of the Telescoping Whip (B) into the socket on top of the Multi-Configuration Coil and tighten hand tight.

The completed assembly should look like that pictured in plate (5).

6. Fully extend the Telescoping Whip.
7. Insert the Counterpoise Connector (J) at the end of a Counterpoise Wire (H) into an empty socket on the side of the Puck hub.
8. Unwind the Counterpoise Wire from the Line Winder (L).
9. Fully extent the Counterpoise Wire in a reasonably straight line away from the antenna.

10. Place a Stake (M) through the Insulator Ring (N) at the end of the Counterpoise Wire.



Plate (5). Bottom Antenna Assembly.

11. Drive the Stake into the ground where the end of the Counterpoise Wire is located.
12. Repeat steps (7) – (11) for the remaining Counterpoise Wires.
13. Connect the end of the Coaxial Cable (F) nearest to the RF Choke into the Coaxial Connector (C) on the bottom of the Multi-Configuration Coil.
This antenna requires Coaxial Cable with an RF Choke
14. Connect the other end of the Coaxial Cable to the radio set.
15. Perform an operational check (see “Operation of the Portable Resonant Vertical” section).

Operation of the Portable Resonant Vertical

We've made operation of the CHA PRV easy. When using the basic antenna, it is tuned on 40 through 10 meters only by adjusting the height of the Multi-Configuration Coil and selecting the number of Counterpoise Wires. Use the following procedure to tune the CHA PRV.

1. When operating from 40 to 10 meters, ensure the Telescoping Whip is fully extended.
2. Connect or disconnect Counterpoise Wires to match the "Number of Radials to Use" column in table (2) for the operating band.
3. Set the initial tuning height of the Multi-Configuration Coil to the value found the "Initial Coil Height" column in table (2) for the operating band. If the antenna is not ground mounted use table (3) for initial settings. The height is measured in centimeters (cm) from the bottom of the Tuning Tube (D) to the bottom of the loading coil, as shown in plate (5). Alternatively, you can move the Tuning Tube UP or DOWN for maximum received noise - although this is not particularly effective due to the effect of body capacitance as you grasp the Tuning Tube.

Band	Number of Counterpoise Wires to Use	Initial Coil Height (cm)	Telescoping Whip Height (cm)	Measured SWR	2:1 Bandwidth (KHz)
40	2	11.0	147	1.7	144
30	1	6.3	147	1.3	416
20	3	3.3	147	1.5	608
17	4	2.2	147	1.6	1104
15	4	1.7	147	1.1	2416
12	4	1.2	147	1.4	3248
10	4	1.0	147	1.0	3968

Table 2. Initial Settings for Ground Mounted Antenna.

4. To make height adjustments to the Multi-Configuration Coil, loosen the Lock Knob (E), grasp the Tuning Tube and gently move the Tuning Tube UP or DOWN. When fine tuning, you can feel the "bump" when the Tuning Tube moves between coil windings.
5. Use the Tuning chart, shown in figure (2), to adjust the CHA PRV for resonance. The chart describes how to find the dip in SWR at resonance (SWR < 2.0:1) on 40 through 10 meters by adjusting the height of the Multi-Configuration Coil.
6. Tighten the Lock Knob finger tight. Do not overtighten.

Reduce the number of Counterpoise Wires if there is only a shallow dip in SWR at resonance. The Tuning Tube may also need a slight (one "bump") adjustment, either up or down as reducing the number of Counterpoise Wires will slightly increase the resonant frequency and adding Counterpoise Wires slightly decreases the resonant frequency.

Band	Number of Counterpoise Wires to Use	Initial Coil Height (cm)	Telescoping Whip Height (cm)	Measured SWR	2:1 Bandwidth (KHz)
40	4	12.8	147	1.4	176
30	2	7.0	147	1.2	416
20	1	3.3	147	1.3	624
17	2	2.2	147	1.8	608
15	3	1.7	147	1.6	1024
12	4	1.0	147	1.4	1648
10	4	0.4	147	1.2	2080

Table 3. Initial Settings for Elevated Antenna.

Note: Antenna height above ground, length of counterpoise wires, number of counterpoises, position of counterpoises, ground conductivity, body capacitance (being near or touching antenna components while tuning), and many other factors profoundly affect antenna resonance. The initial settings in tables (2) and (3) were made in a typical operating environment, but could vary greatly from your values.

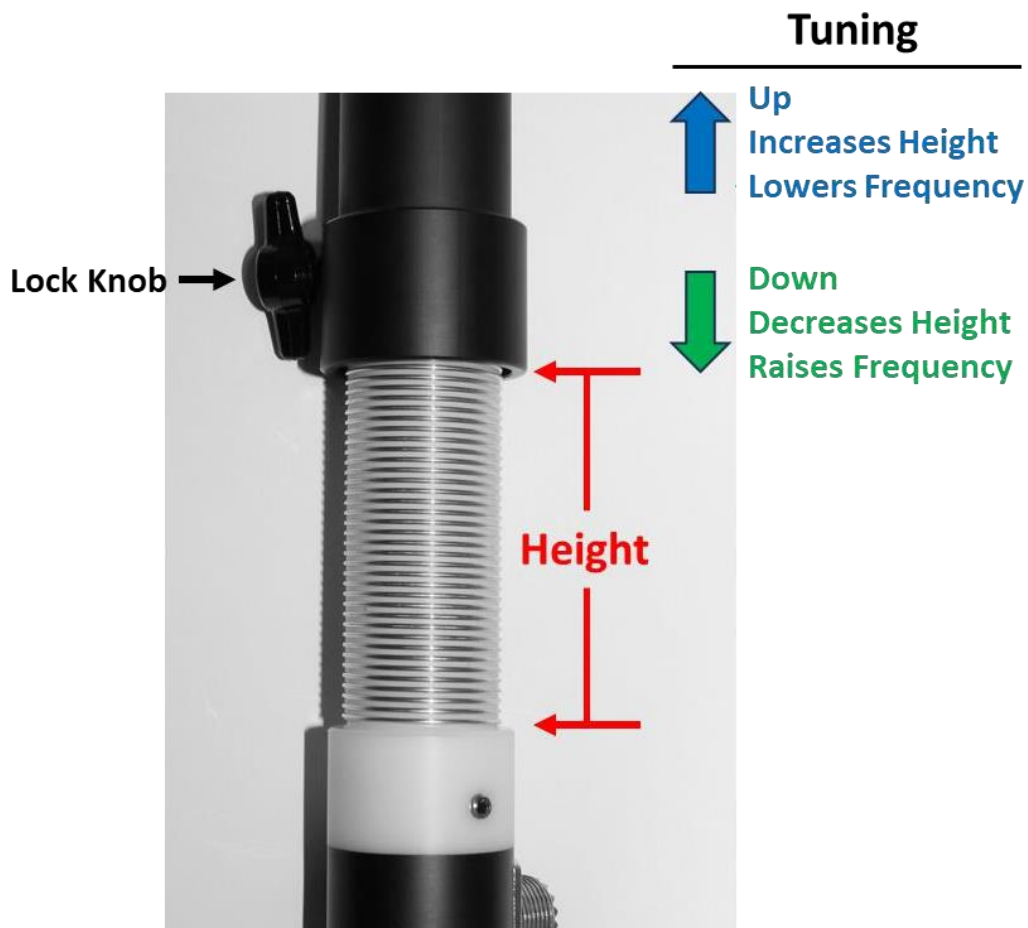

Plate 5. Tuning Adjustment.

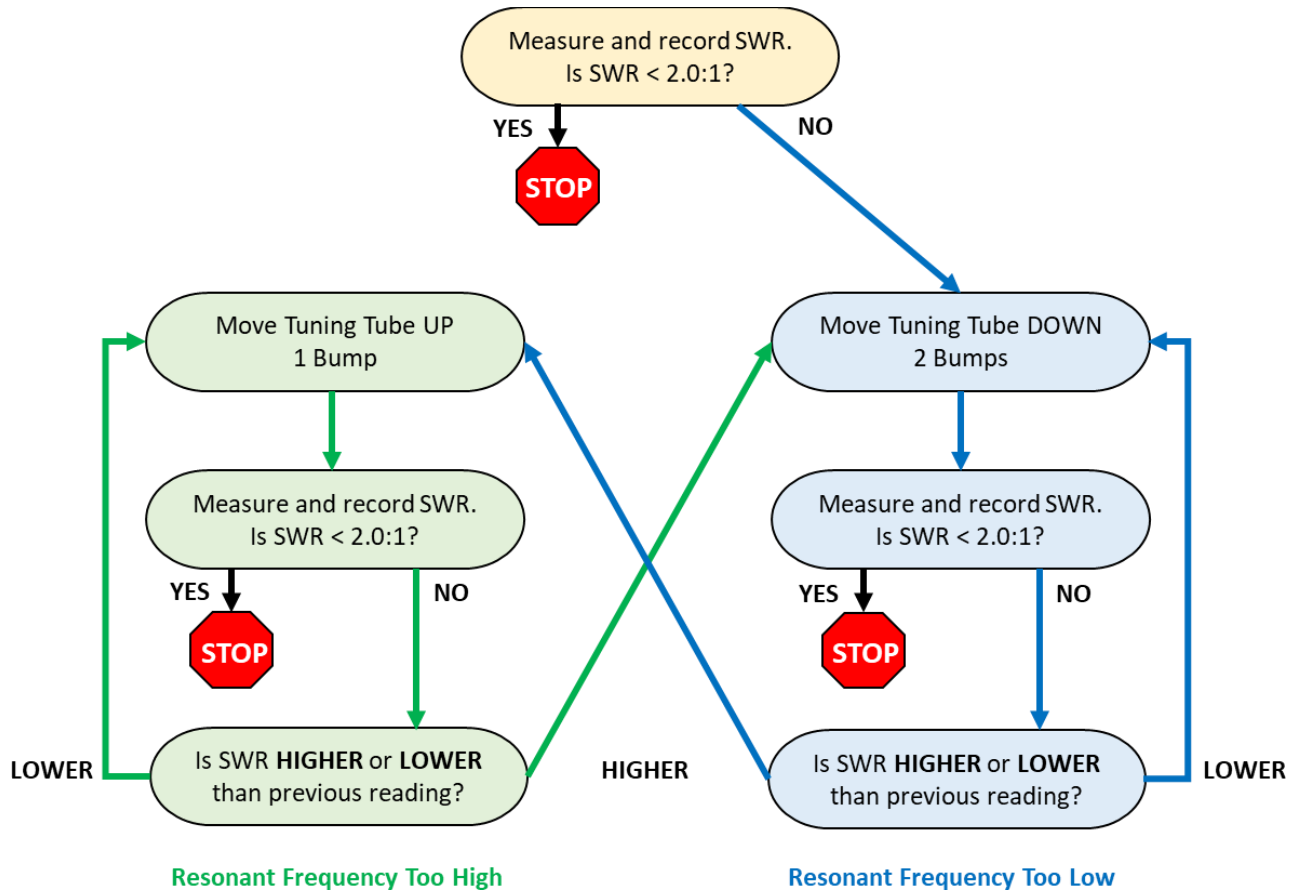

Figure (2). Tuning Chart (40 – 10 meters).

Operation on 6 and 2 meters

The CHA PRV can be used on the 6 and 2 meter ham bands. To operate on these band:

- Fully lower the Multi-Configuration Coil.
- On 6 meters, install one or more Counterpoise Wires per that are ¼ wavelength long or use the optional Stinger Kit.
- Lower the Telescoping Whip to the value shown in Table (4).
- Make fine adjustments in the length of the Telescoping Whip until the SWR is less than 2.0:1.

Band	Whip Length (in./cm)	Radial Length (in./cm)
6	40/101	48/122
2	29/75	None, 1/2 wave

Table 4. 6 and 2 meter Whip Lengths

Tuning Theory

Unlike most portable antennas from Chameleon Antenna™, which use a broadband design, the CHA PRV is a resonant antenna. Simply put, an antenna is at resonance when Reactance (X) is zero and the Impedance (Z) is only Resistive (R). The primary benefit of a resonant antenna is that you do not need an antenna tuner. Less equipment is important to operators doing POTA, SOTA, and other extreme portable operations, for which the CHA PRV is designed.

While attempting to tune the CHA PRV, the concept of resonance and what resonance *looks* like is important to help you quickly tune the antenna. Figure (3) shows an actual photograph from an antenna analyzer for the CHA PRV tuned for 20 meters. When you initially set the height of the Multi-Configuration Coil, using Tables (2) or (3), you don't know which region on the graph you will be, as an SWR meter only provides a number. Region (1) is where the SWR is very high and nearly asymptotic because the antenna is too long. Conversely, Region (4) is where the SWR is very high and nearly asymptotic because the antenna is too short.

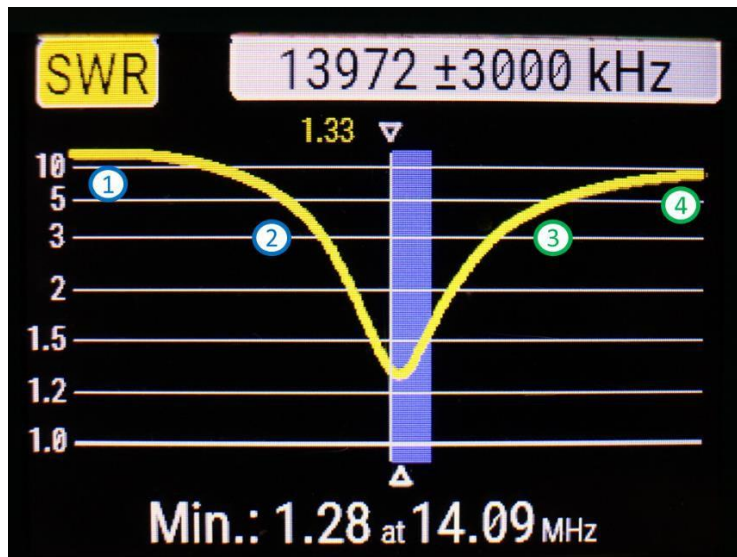

Figure 3. Possible Initial Tuning Regions.

Without an antenna analyzer, you can't determine if you are near Region (1) or (4). In either case, the procedure will eventually work towards antenna resonance - it just might take a number of iterations. The maximum number of iterations needed to achieve an SWR of less than 2.0:1 was seven and the minimum was three during testing of the tuning procedure. Regions (2) and (3) are where the values of height from the tables were designed to start. Regions (2) and (3) indicate approaching resonance, but the antenna is still slightly too long or short, respectively. The procedure should step you to resonance in only a few iterations. The goal of the procedure is to achieve an SWR of less than 2.0:1, which indicates you are very close to resonance. If you started at either Regions (1) or (4), record the new height at resonance for use in future setups.

Recovery Procedure

To recover the CHA PRV, perform the following steps:

1. Disconnect the Coaxial Cable from the radio set and antenna.
2. Carefully roll (do not twist) the Coaxial Cable.
3. Unplug the Counterpoise Wires from the Puck hub.
4. Pull the Stakes from the ground.
5. Wind the Counterpoise Wires onto their individual Line Winders.
6. Collapse the Telescoping Whip and remove it from the Multi-Configuration Coil.
7. Detach the Multi-Configuration Coil from the Spike Mount. *You can leave the Puck hub attached to the Multi-Configuration Coil.*
8. Pull the Spike Mount from the ground.
9. Check deployment area for misplaced antenna components.
10. Remove dirt from antenna components and inspect them for signs of wear.
11. Store components together in a tactical pack.

Troubleshooting

1. Ensure Telescoping Whip, Multi-Configuration Coil, Puck hub, Coaxial Cable, and Counterpoise Wire connections are securely attached and connected.
2. Ensure that the correct number of Counterpoise Wires are used and that they are the proper length. Too many/too long Counterpoise Wires can result in an SWR greater than 2.0:1, even at resonance.
3. Inspect antenna components, especially the Coaxial Cable, for breakage or signs of strain. Replaced damaged components.
4. Be sure to check any patch cables or adapters used.
5. If still not operational, connect a Standing Wave Ratio (SWR) Power Meter and check SWR.
6. If after tuning, the SWR is still greater than 5:1, replace Coaxial Cable assembly. *Most problems with antenna systems are caused by the coaxial cables, connectors, and adapters.*
7. If still not operational, contact Chameleon Antenna™ for technical support.

Modular Upgrades

The CHA PRV was designed to be modular – not only can it use optional accessories developed specifically for the new CHA PRV antenna system, but also many existing components and accessories from other Chameleon Antenna™ products. Some upgrades shown below may be included in the CHA PRV SOTA and POTA kits, but can also be used with other Chameleon Antenna™ products you already own. These upgrades will increase the utility of your Chameleon Antenna™ products and are available for purchase at www.chameleonantenna.com or from your dealer.

Variable Length Counterpoise System



The Variable Length Counterpoise system is a highly flexible method of providing the CHA PRV a necessary counterpoise from 5.3 to 54.0 MHz (60 – 6 meters). Used with the Puck hub, it would be an excellent upgrade for the MPAS 2.0 or MPAS Lite antennas. It include 34 ft. of high-visibility light gauge wire, which can be placed directly on the ground or elevated. Figure (4) shows the crank reel installed in an elevated configuration using a trekking pole and paracord suspension line to enable rapid adjustment of the counterpoise length. Many configurations are possible. The inset in Figure (4) shows the Variable Length Counterpoise placed directly on the ground.

To use the Variable Length Counterpoise with the CHA PRV:

1. Fully extend the Counterpoise Wire.
2. Tune the CHA PRV using the “Operation of the Portable Resonant Vertical” procedure.
3. If the SWR is greater than 2.0:1, crank or roll in several feet of Counterpoise Wire and try again. Repeat this step until SWR is less than 2.0:1. You can tell that the Counterpoise Wire is too long if there is only a shallow dip in SWR at resonance. The Tuning Tube may also need a slight (one “bump”) adjustment, either up or down as shortening the Counterpoise Wire increases the resonant frequency and lengthening it lowers the resonant frequency.

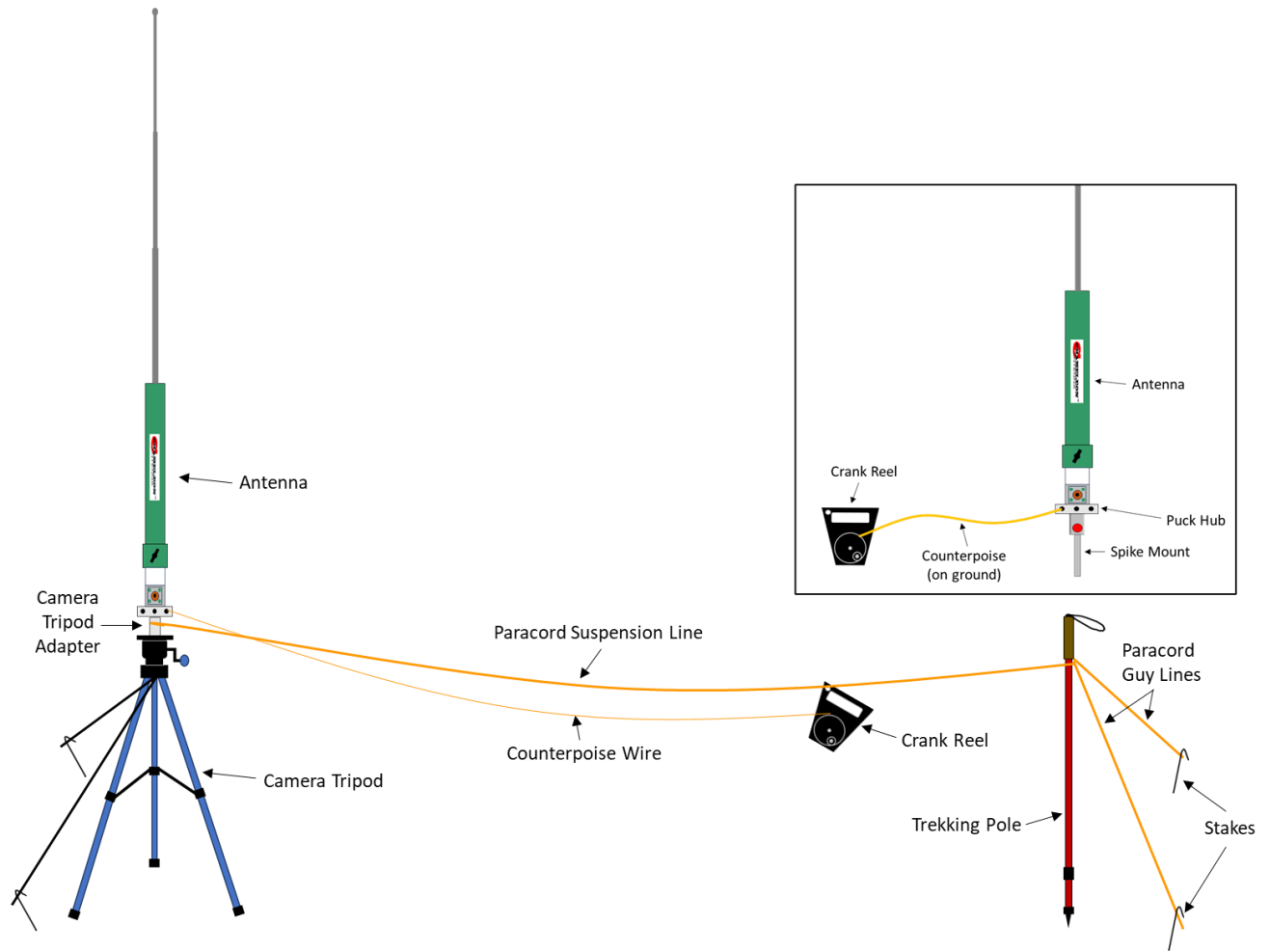

Figure 4. Variable Length Counterpoise Setup Methods.

Stinger Kit



The Stinger Kit provides a rigid ground plane of six 4 ft. rigid radials and a 48 in. rigid whip “stinger” for use with the CHA PRV when there is not room for longer wire counterpoises or to fully extend the 58 in. Telescopic Whip. It is perfect for an RV or an apartment balcony. It enables operation on 7.0 through 54.0 MHz (40 through 6 meters). A tuner may be needed on 40 meters. You will need to use the 58 in. Telescopic Whip collapsed to the correct length to operate on 6 meters.

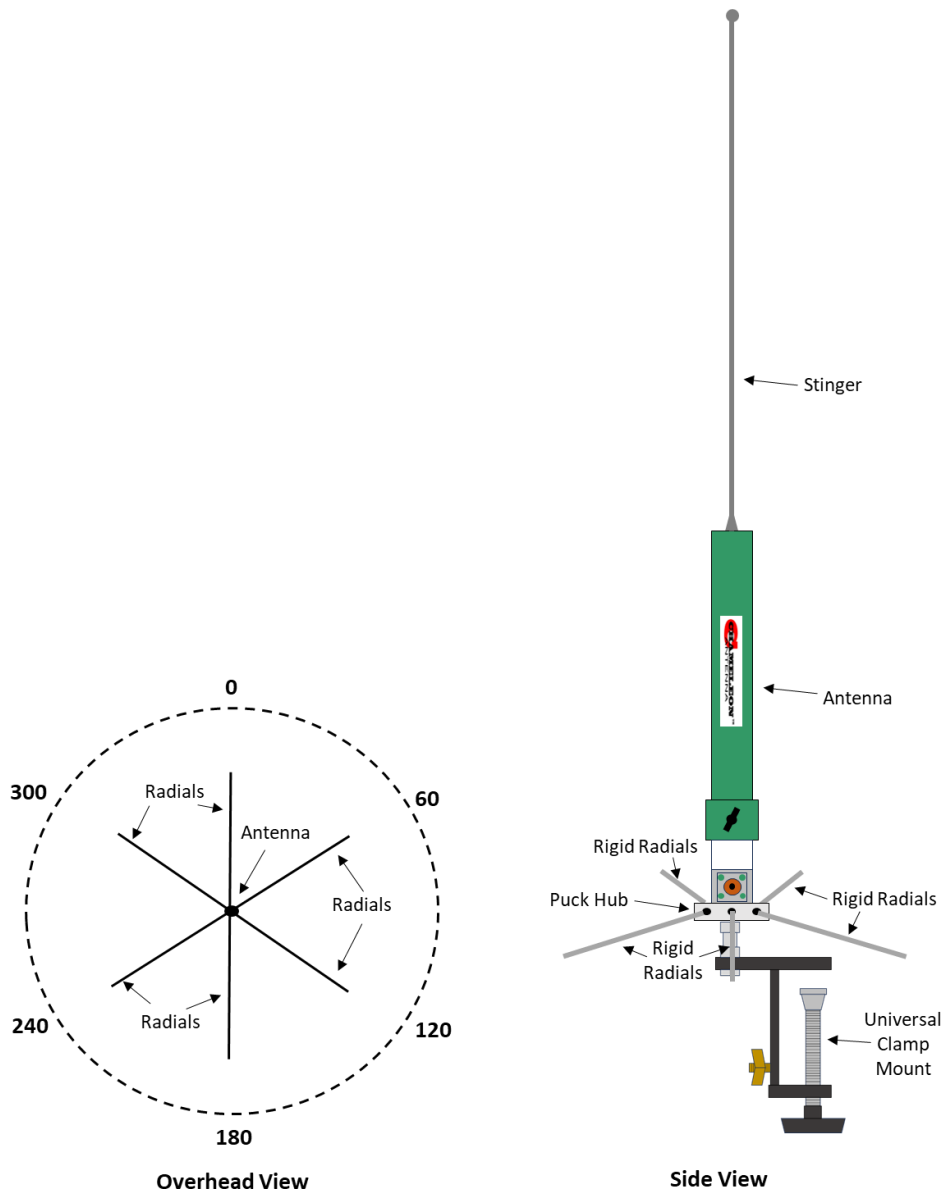

Figure 5. Stinger Kit Setup.

Universal Clamp Mount



The Universal Clamp Mount (CHA UCM) is a heavy-duty clamp-style mount intended for use on balcony railings, tables, and other fixtures with flat horizontal surfaces with edges. It is suitable for semi-permanent installation. The CHA PRV with the Stinger Kit would be ideal for an RV, apartment, or condominium.

CHA MIL 2.0 WHIP



- **Type:** Military-style collapsible whip antenna
- **Frequency:** Approximately 5 to 22 MHz continuous (includes the 60 - 15 meter ham bands), when used with the CHA PRV
- **Length:** 9 ft. 4 in. extended, less than 20 in. collapsed
- **Color:** OD Green
- **Description:** Its design has been borrowed from similar antennas utilized by many armies all over the world. This antenna is part of the Modular Portable Antenna System (MPAS) 2.0 and will enable operation on 60 meters and will improve performance on 40 through 15 meters.

CHA SS17



- **Type:** Stainless Steel telescoping whip antenna
- **Frequency:** Approximately 4 to 14 MHz continuous (includes the 60 - 30 meter ham bands), when used with the CHA PRV
- **Length:** 17 ft. extended, 27 in. collapsed
- **Color:** Chrome
- **Description:** A sturdy 10 section telescoping whip. Similar to the supplied 58 in. telescoping whip, but longer. This antenna is part of the MPAS Lite and will enable operation on 60 meters and improve performance on 40 and 30 meters.

Jaw Mount



The Jaw Mount (CHA JAWMOUNT) is a portable clamp-style mount capable of attaching to a variety of objects, such as fence posts, poles, tables, ladders, etc. It would be perfect for mounting the CHA PRV to a picnic table when doing a POTA activation.

Camera Tripod Adapter



The Camera Tripod Adapter is an optional new product that enables any Chameleon Antenna™ with a 3/8" x 24 mount to be attached to a heavy-duty camera tripod or monopod. We have seen advertisements for Trekking Poles with a camera attachment and we think this could possibly be the ultimate setup for hiking and SOTA!

Accessories

In addition to the modular components already described, the following accessories are available for purchase from Chameleon Antenna™. Go to www.chameleonantenna.com for current prices and availability.

- **COIL LOCK** – The Coil Lock is a device used to help support the added weight and momentum of the CHA SS17 17 ft. telescoping whip when used with the CHA PRV antenna.
- **CHA DPACK** – A small to medium bodied/shoulder pack that is perfect to store the components of the CHA PRV and other portable station equipment ready for your next deployment.

Specifications

- **Frequency Range:** Covers 40 – 2 meter Amateur Service bands. No tuner required. Approximately 5.4 MHz through 37.0 MHz continuous as a base-loaded quarter wave with 58 in. Telescoping Whip fully extended and tuned by adjustment of the height of the Multi-Configuration Coil. Approximately 37.0 through 100.0 MHz continuous with Multi-Configuration Coil all the way down and tuning accomplished by varying the length of the Telescoping Whip. 144.0-148.0 MHz as a base-fed half wave.
- **Power Handling:** 500W intermittent Duty Cycle (SSB Phone), 300W all other modes.
- **Height:** Approximately 80 in. fully assembled / extended.
- **SWR:** Typically, less than 2:1 at resonance.
- **Bandwidth:** See tables (2) and (3).
- **Weight:** Approximately 3 lbs.
- **Color:** Mostly green with a stainless steel whip.
- **Setup Time:** One operator, approximately 10 minutes.

References

1. Silver, H. Ward (editor), 2013, *2014 ARRL Handbook for Radio Communications*, 91st Edition, American Radio Relay League, Newington, CT.
2. 1987, *Tactical Single-Channel Radio Communications Techniques (FM 24-18)*, Department of the Army, Washington, DC.
3. Turkes, Gurkan, 1990, *Tactical HF Field Expedient Antenna Performance Volume I Thesis*, U.S. Naval Post Graduate School, Monterey, CA.

Chameleon Antenna™ Products

Go to <http://chameleonantenna.com> for information about quality antenna products available for purchase from Chameleon Antenna™ – The Portable Antenna Pioneer.

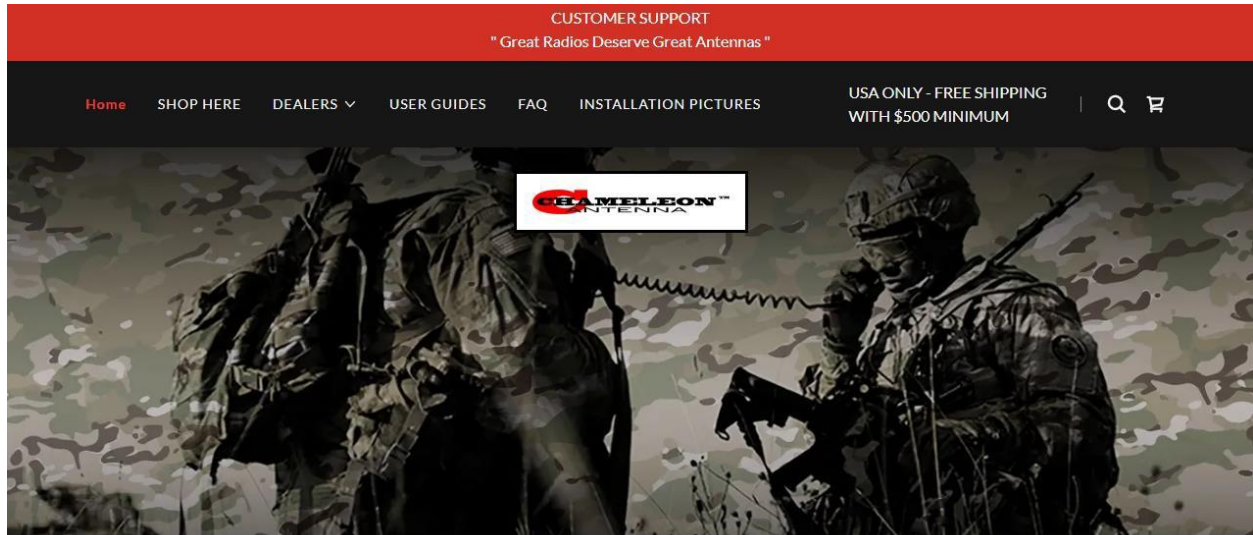

THE PORTABLE ANTENNA PIONEER BECAUSE GREAT RADIOS DESERVE GREAT ANTENNAS

Chameleon Antenna™ products are available from these great dealers:

HRO
DX ENGINEERING
GIGAPARTS
WIMO
MOONRAKER
RADIOWORLD UK
R&L ELECTRONICS
ML&S MARTIN LYNCH
PILEUPDX
LUTZ-ELECTRONICS
RADIOWORLD CANADA
GPS CENTRAL
PASSION-RADIO.COM